

	MERIS VA	MERIS-VA System Architecture Theoretical Basis Document
--	---------------------	--

Title: **MERIS-VA System Architecture Theoretical Basis Document**

Doc. no:

Issue: 1

Revision: 1

Date: 16.3.2000

	<u>Function</u>	<u>Name</u>	<u>Company</u>	<u>Signature</u>	<u>Date</u>
Prepared:		C. Brockmann	SCICON		
		N. Fomferra	SCICON		
Approved:	Project Manager	C. Brockmann	SCICON		
Released:					

	MERIS VA	Doc : Name :MERIS-VA System Architect. Theoretical Basis Document Issue : 1 Rev : 1 Date : 16.3.2000 Page : ii
--	-------------------------------	--

External Distribution

<u>Name</u>	<u>Quantity</u>
-------------	-----------------

Change Record

<u>Issue</u>	<u>Revision</u>	<u>Date</u>	<u>Description</u>	<u>Approval</u>
1		1.3.99	initial issue	
1	1	16.3.2000	Level 2 ADD added Appendix 1: CRR added	

<h1 style="margin: 0;">MERIS</h1> <h2 style="margin: 0;">VA</h2>	Doc : Name :MERIS-VA System Architect. Theoretical Basis Document Issue : 1 Rev : 1 Date : 16.3.2000 Page : iii
--	---

Table of Contents

1	INTRODUCTION.....	4
1.1	GENERAL	4
1.2	PURPOSE AND SCOPE	4
1.3	DEFINITIONS, NOTATIONS AND CONVENTIONS.....	5
2	REFERENCES AND ABBREVIATIONS	6
2.1	APPLICABLE DOCUMENTS	6
2.2	REFERENCE DOCUMENTS	6
2.3	ABBREVIATIONS.....	6
3	ARCHITECTURE OVERVIEW.....	8
3.1	SYSTEM CONTEXT	8
3.2	SUBSYSTEMS	11
3.2.1	<i>Level 2 Data</i>	12
3.2.2	<i>Level 3 Data</i>	12
3.2.3	<i>Visualization of Validation Data</i>	12
3.2.4	<i>Formatting</i>	12
3.3	AUXILIARY DATA PRODUCTS	12
3.4	THE MERIS-VA GRID	12
4	ARCHITECTURE DESCRIPTION.....	13
4.1	LEVEL 2 DATA	13
4.1.1	<i>Architectural breakdown</i>	13
4.1.1.1	Detailed Description	14
4.2	LEVEL 3 DATA	20
4.2.1	<i>Level 3 plug-in management</i>	20
4.2.2	<i>Level 3 database management</i>	21
4.3	GENERATION OF GENERIC LEVEL 3 PRODUCTS.....	22
4.4	GENERATION OF LEVEL 3 CLOUD AND WATER VAPOUR PRODUCTS.....	23
4.5	GENERATION OF LCC	23
5	LEVEL 2 ADD (DRAFT).....	25
5.1	USE CASES	25
5.2	LOGICAL STRUCTURE	27
5.3	PHYSICAL STRUCTURE	27
5.4	ARCHITECTURE DETAILS	28
6	APPENDIX.....	31
6.1	COMPUTATIONAL RESOURCE DOCUMENT	31
6.1.1	<i>Scope of the document</i>	33
6.1.2	<i>Applicable Documents</i>	33
6.1.3	<i>disk space requirements</i>	33
6.1.3.1	MERIS-VA Products Overview.....	33
6.1.3.2	Input Products.....	33
6.1.3.3	Level 2 intermediate products	34
6.1.3.4	Level 3 intermediate products	34
6.1.3.5	User products	37
6.1.3.6	Summary	37
6.2	PLUG – IN CONCEPT FOR THE MERIS-VA PROCESSOR.....	38
6.3	MEMORY MAPPED FILE I/O FOR LARGE FILES.....	38

<h1 style="margin: 0;">MERIS</h1> <h2 style="margin: 0;">VA</h2>	Doc : Name :MERIS-VA System Architect. Theoretical Basis Document Issue : 1 Rev : 1 Date : 16.3.2000 Page : 4
--	---

1 INTRODUCTION

1.1 General

This document is the system architecture theoretical basis document for the MERIS-VA processor. It covers the processing for the generation of the MERIS-VA Level 2 and Level 3 products, as defined in MERIS-VA Input /Output Data Definition document (RD1).

The definition of the MERIS instrument processing software for the routine on ground processing of MERIS Value Added data is a key activity in the overall definition and implementation of the MAPP subproject “operational products”.

1.2 Purpose and Scope

This document provides a complete architectural overview of the MERIS-VA processing chain. It provides upper level information relevant to and supporting the MERIS processing specification documentation which is shown in diagram 1.2-1 below.

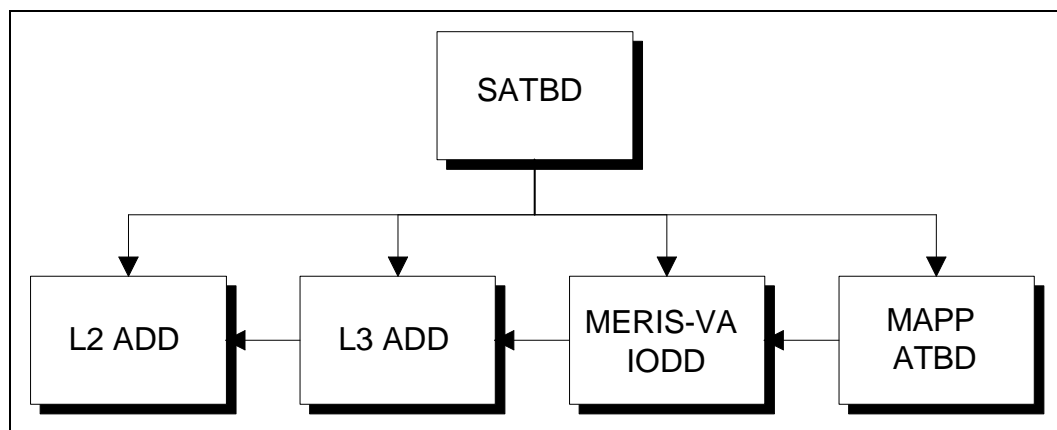

Figure 1 MERIS-VA Processing documentation tree

The processing model is described, based on objectives and current knowledge. A top-down structured analysis (SA) breakdown is performed into basic functional elements and identifying all interfaces. Each of these basic elements is described in detail in the relevant Algorithm Theoretical Basis Document and in the Detailed Processing Model Document (RD2, RD3).

For each basic functional element, a critical review is performed, and a global algorithm assessment is provided under the form of a summary table, which gives:

1. the criticality of the function : how fundamental the function is in the overall processing chain: rated from **low** to **critical**;
2. the complexity of the algorithm : rated from **simple** (about 50 statements or less) to **complex** (more than 200 statements);
3. the maturity /stability of the algorithm, rated **research** for unsolved problem as of today, **semi-operational** for specific aspects still subject to changes, and **operational** for purely engineering operations;
4. the level of complexity of the interface, from **simple** to **complex**.

<h1 style="margin: 0;">MERIS</h1> <h2 style="margin: 0;">VA</h2>	Doc : Name :MERIS-VA System Architect. Theoretical Basis Document Issue : 1 Rev : 1 Date : 16.3.2000 Page : 5
--	---

1.3 Definitions, Notations and Conventions

A Product is a data set identified within the MAPP project, and whose description exists in the Input /Output Data Definition (RD1).

There are **input products** : MERIS standard Level 1 and 2 products, auxiliary products, and **output products**: Level 2 products, Level 3 products, browse product (TBC).

A **Line** is

a set of data simultaneously acquired by MERIS
by extension, the instant where these data are acquired

A **Sample** is a single MERIS measurement or derived quantity (column, band, line in the Level 1 and Level 2 products).

A **Pixel** is the set of samples representing all the bands at a given place sampled by MERIS (column, line) or in the product (column, line).

A **grid cell** is the set of samples included in one box of the MERIS-VA Level 3 grid (see section 3.4).

The subscripts used shall be b: band; k: column; f: frame. * represents the whole range of an index.

In all SA – data flow diagrams the following symbols are used as specified in Figure 2.

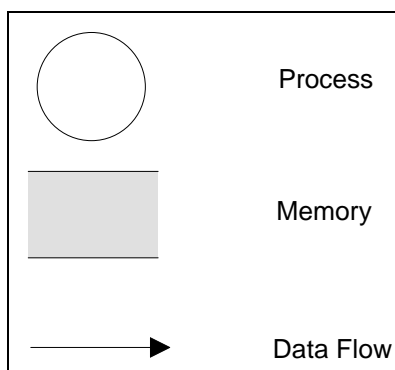

Figure 2 Definition of symbols used in flow diagrams

Physical notations shall follow the conventions in the "6S User Guide" (RD4).

For each basic functional element, a summary table is given, which in the example shown below means that the function has a high criticality, an operational simple algorithm, and a simple interface :

Criticality	LOW	MEDIUM	HIGH
Algorithm complexity	SIMPLE	MEDIUM	COMPLEX
Maturity / stability	OPERATIONAL	SEMI OPERATIONAL	RESEARCH
Interface	SIMPLE	MEDIUM	COMPLEX

MERIS VA	Doc : Name :MERIS-VA System Architect. Theoretical Basis Document Issue : 1 Rev : 1 Date : 16.3.2000 Page : 6
-------------------------------	---

2 REFERENCES AND ABBREVIATIONS

2.1 Applicable Documents

none

2.2 Reference Documents

- RD1. Input / Output Definition Document (in preparation)
- RD2. Algorithm Theoretical Basis Document
- RD3. Detailed Processing Model (in preparation)
- RD4. Second Simulation of the Satellite Signal in the Solar Spectrum (6S) User guide v.1, Laboratoire d'Optique Atmospherique
- RD5. Tables Generation Requirement Document (in preparation)

2.3 Abbreviations

AD	Applicable Document
AVHRR	Advanced Very High Resolution Radiometer
BOAVI	Bottom Of Atmosphere Vegetation Index
CCD	Charge Coupled Device
CD-ROM	Compact Disc, Read Only Memory (trade mark)
DDV	Dense dark vegetation
DEM	Digital Elevation Model
DFD	Deutsches Fernerkundungsdatenzentrum
DPM	Detailed Processing Model
ESA	European Space Agency
FR	Full Resolution
GS	Ground Segment
IODD	Input /Output Definition Document
JPEG	Joint Photographic Experts Group
L1b	Level 1 b
L2	Level 2
LCC	Land cover classification
MDS	Main data set
MERIS	Medium Resolution Imaging Spectrometer
MJD2000	Modified Julian Day 2000
MTF	Modulation Transfer Function
NDVI	Normalised Differential Vegetation Index
NN	Neural net
PCD	Product Confidence Data
PCI	Principle Component Inversion
PSM	Processing System Management
RD	Reference Document
RR	Reduced Resolution
SA	Structured Analysis
sqq.	and the following ones
TBC	To Be Confirmed
TBD	To Be Defined

	MERIS VA	Doc : Name :MERIS-VA System Architect. Theoretical Basis Document Issue : 1 Rev : 1 Date : 16.3.2000 Page : 7
--	-------------------------------	---

TOA	Top Of Atmosphere
TOAR	Top Of Atmosphere Radiance
TOAVI	TOA Vegetation Index
UTC	Universal Time Coordinate
VA	Value added
WGS	World Geodetic Standard

<h1 style="margin: 0;">MERIS</h1> <h1 style="margin: 0;">VA</h1>	Doc : Name :MERIS-VA System Architect. Theoretical Basis Document Issue : 1 Rev : 1 Date : 16.3.2000 Page : 8
--	---

3 ARCHITECTURE OVERVIEW

3.1 System Context

In Figure 3, the context of the MERIS-VA processor, i.e. its relationship with the external environment, is shown. The MERIS-VA main process (ID 0) has the objective to generate the MERIS-VA products. The production requests are either issued by an Operator or a Controlling Process. The latter will be probably the PSM (Processing System Management) of the DFD facility.

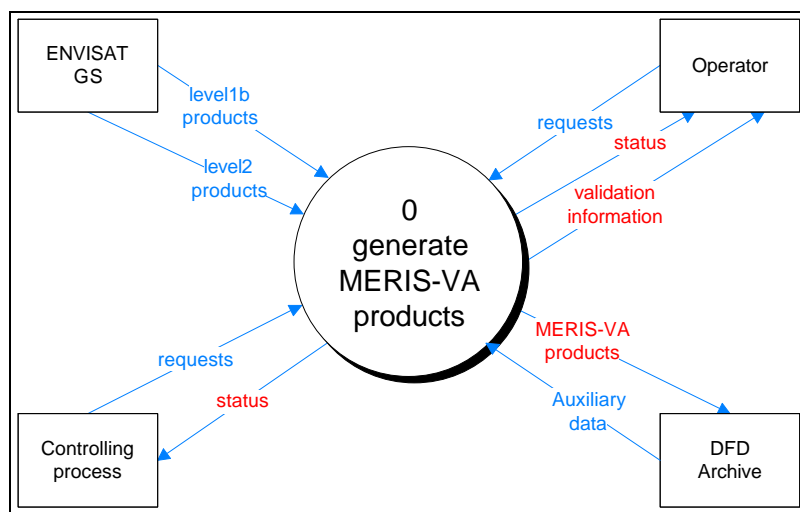

Figure 3 MERIS-VA Context

The Main Process gets the required Level 1b and Level 2 products for a processing request from the ENVISAT Ground Segment (ENVISAT GS), i.e. the ESA – MERIS processor. In addition, data tables with auxiliary parameters (e.g. coefficients for data conversion, atmospheric parameters, previously generated Level 2 products needed for Level 3 products) are retrieved from the DFD Archive. In the latter, the final results of the process, i.e. the Level 2 and 3 products are written.

If the PSM is used, the retrieval of all input parameters as well as the proper storage of the output parameters is performed by that system. All data exchange is performed through a Cache area, and the main Process uses this Cache area as a single input / output storage location.

The MERIS-VA processes work of the Standard Level 1b and Level 2 products generated by the ESA processor. Table 1 and Table 2 summarise these basic input data. The Level 1b product consists of calibrated top of atmosphere reflectances in all 15 MERIS bands and a set of flags indicating the data quality. In addition, on a sub grid (every 16th pixel) the geo-location, the viewing geometry and meteorological data are available. The Level 2 product depends on the surface type of the viewed pixel. Therefore, in Table 2 the contents of some main data sets depends on the surface type. The different types are shown in Figure 4: Water, Land and Clouds. Waters are further separated into Case-I and Case-II, and Land into DDV and non DDV, but without influence on the product content (however, with strong influence on the standard processing). Above all surfaces, the surface reflectances in all bands except the

<h1>MERIS</h1> <h2>VA</h2>	Doc : Name :MERIS-VA System Architect. Theoretical Basis Document Issue : 1 Rev : 1 Date : 16.3.2000 Page : 9
----------------------------	---

O2A and water vapour absorption bands are given. Also, quality flags are specified for all surface types.

<i>MDS s</i>	<i>Ocean</i>
MDS-1	TOA reflectance 412.5
MDS-2	TOA reflectance 442.5
MDS-3	TOA reflectance 490
MDS-4	TOA reflectance 510
MDS-5	TOA reflectance 560
MDS-6	TOA reflectance 620
MDS-7	TOA reflectance 665
MDS-8	TOA reflectance 681.25
MDS-9	TOA reflectance 705
MDS -10	TOA reflectance 753.75
MDS-11	TOA reflectance 760
MDS-12	TOA reflectance 775
MDS-13	TOA reflectance 865
MDS-14	TOA reflectance 890
MDS-15	TOA reflectance 900
MDS-16	Quality flags

Table 1 *MERIS Standard Level 1b products. MDS is the Main Data Set and can be understood as a record in the product. TOA stands for Top Of Atmosphere.*

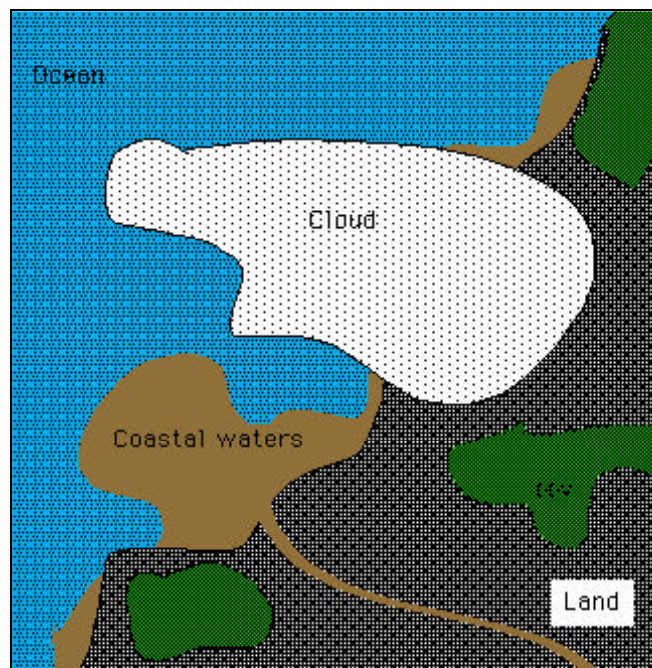

Figure 4 *MERIS Standard Surface Types*

<h1 style="margin: 0;">MERIS</h1> <h2 style="margin: 0;">VA</h2>	Doc : Name :MERIS-VA System Architect. Theoretical Basis Document Issue : 1 Rev : 1 Date : 16.3.2000 Page : 10
--	--

<i>MDS s</i>	<i>Ocean</i>	<i>Land</i>	<i>Coud</i>
MDS-1	rs 412.5	rs 412.5	rs 412.5
MDS-2	rs 442.5	rs 442.5	rs 442.5
MDS-3	rs 490	rs 490	rs 490
MDS-4	rs 510	rs 510	rs 510
MDS-5	rs 560	rs 560	rs 560
MDS-6	rs 620	rs 620	rs 620
MDS-7	rs 665	rs 665	rs 665
MDS-8	rs 681.25	rs 681.25	rs 681.25
MDS-9	rs 705	rs 705	rs 705
MDS -10	rs 753.75	rs 753.75	rs 753.75
MDS-11	rs 775	rs 775	rs 775
MDS-12	rs 865	rs 865	rs 865
MDS-13	rs 890	rs 890	rs 890
MDS-14	Water Vapour Content	Water Vapour Content	Water Vapour Content
MDS-15	Algal pigment I	TOAVI	Cloud top pressure
MDS-16	TSM - YS	Spare	Spare
MDS-17	Algal pigment II	BOAVI	Spare
MDS-18	FPAR	Surface pressure	Cloud albedo
MDS-19	Aerosol t & e	Aerosol t & e	Cloud t & type
MDS-20	Flags	Flags	Flags

Table 2 *MERIS Standard Level 2 Products. MDS is a Main Data Set. RS is a surface reflectance. TSM is total suspended matter, FPAR the Fractional Photosynthetically available radiation, TOAVI and BOAVI the Top of Atmosphere and Bottom of Atmosphere Vegetation Indices.*

Table 3 shows the MERIS-VA Level 2 and Level 3 products which are generated by the processor. The Level 2 products are provided in satellite coordinates with geolocation appended. The Level 3 products are resampled to a standard grid, which is introduced in section 3.4 and described in detail in ATBD 10.

All Level 2 and Level 3 products are described in the related ATBDs.

	<i>Level – II</i>	<i>Level – III</i>
Wasser	<ul style="list-style-type: none"> • Chlorophyll, • Gelbstoff, • Schwebstoff • (Nordsee, Ostsee, Bodensee) 	<ul style="list-style-type: none"> • Ostsee: wie L2, monatl. Mittelwerte • M1 Karte
Atmosphäre	<ul style="list-style-type: none"> • Aerosoltyp, • optische Dicke in der Küstensor 	<ul style="list-style-type: none"> • wie L2, monatl. Mittelwerte. • M8 Karte
	<ul style="list-style-type: none"> • Wolkenhöhe • optische Dicke von Wolken • Wolkenalbedo • Wasserdampf 	<ul style="list-style-type: none"> • ISCCP Wolkentypen (oder Erweiterung) • Wasserdampf in ISCCP Wolken Kategorien

<h1 style="margin: 0;">MERIS</h1> <h1 style="margin: 0;">VA</h1>	Doc : Name :MERIS-VA System Architect. Theoretical Basis Document Issue : 1 Rev : 1 Date : 16.3.2000 Page : 11
--	--

		<ul style="list-style-type: none"> • Statistik in vertikalen Schichten: <ul style="list-style-type: none"> • Wolkenhäufigkeit • optische Dicke von Wolken • Wolkenhöhe • Wasserdampf • M16 Karte
Land	<ul style="list-style-type: none"> • NDVI 	<ul style="list-style-type: none"> • NDVI monatl. & jährl. Mittel • Landbedeckungsklassifikation • M1 Karte

Table 3 MERIS-VA Level 2 and Level 3 products

3.2 Subsystems

The main process introduced before has 4 subsystems (Figure 5):

1. The generation of Level 2 data
2. The generation of Level 3 data
3. The visualisation of validation data
4. The output product formatting

The first two sub processes receive the external processing request. The level 2 data generation needs from external both the Level 1b and Level 2 products, while the Level 3 process only requires Level 2 standard products. Both processes deliver validation data for inspection and quality control to the visualisation process.

A key element in this level are two storages, one for the produced MERIS-VA level 2 and one for the Level 3 data. The Level 2 storage contains for every pixel a data structure with all available information, i.e. Level 1b, Level 2 standard and VA, geolocation, geometry, etc. The level 3 storage contains on the MAPP Level 3 grid the Level 3 products and statistical information.

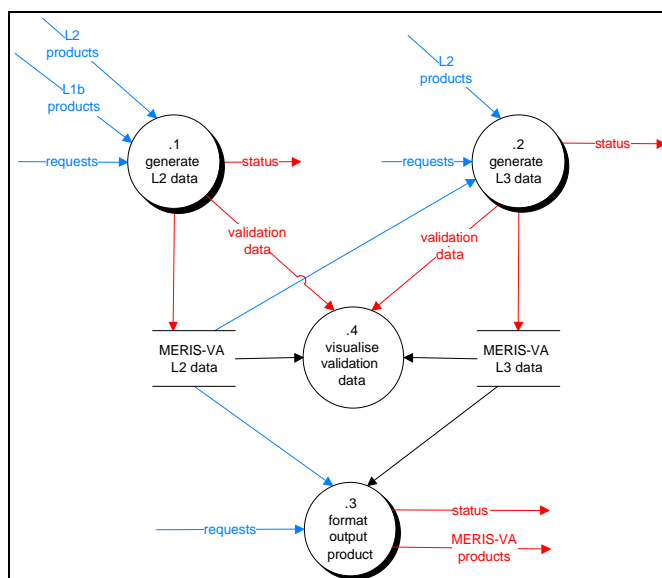

Figure 5 MERIS-VA subsystems

	MERIS VA	Doc : Name :MERIS-VA System Architect. Theoretical Basis Document Issue : 1 Rev : 1 Date : 16.3.2000 Page : 12
--	-------------------------------	--

3.2.1 Level 2 Data

The level 2 generation process is triggered by production requests, which include the products to be generated and their time and geographical specification. Status information is provided back to the invoking process, and the resulting products are stored in the level 2 data storage.

3.2.2 Level 3 Data

The level 3 generation process is triggered by production requests, which include the products to be generated and their time and geographical specification. Status information is provided back to the invoking process, and the resulting products are stored in the level 3 data storage.

3.2.3 Visualization of Validation Data

The visualisation process is an interactive user interface which permits a visualisation of the data in the two storages for quality control. It will be an independed process which can be run in any remote environment which has access to the data storages.

3.2.4 Formatting

The formatting works on the Level 2 and Level 3 data storages and performs two types of processing: the transformation of the data into any of the TBD projections and then the packing into any of the TBD user product formats.

3.3 Auxiliary Data Products

Data bases of input parameters for MERIS processing are also called "data tables" throughout this document. The detailed format of these data tables is provided in RD1; their contents and generation is described in RD5.

3.4 The MERIS-VA Grid

The basis for the generation of the MERIS-VA level 3 products is the Level 3 grid Figure 6. See also ATBD 10 and 11 for details of the generation of the Level 3 products on that grid.

The grid is consists of 12800 x 12800 grid cells with 300m extension in both directions. It has an extension of 3840 km x 3840 km. The receiving station Neustrelitz is in the centre of the grid, which covers the whole area of reception. The transformation of a geographical location into the corresponding grid cell is given in ATBD 10.

This grid is called the M1 grid. A coarser grid, where n grid cells in every direction are combined, is called the Mn grid. Such a grid has a grid size of n x 300m in every direction and has 12800/n grid cells in every direction. For example, the M5 grid has 2560 x 2560 grid cells with a size of 1500 x 1500m.

It is possibly forseen to extend the grid in all directions slightly in order to cover also those areas, where Neustrelitz still receives some data.

<h1>MERIS</h1> <h1>VA</h1>	Doc Name : MERIS-VA System Architect. Theoretical Basis Document Issue : 1 Rev : 1 Date : 16.3.2000 Page : 13
----------------------------	---

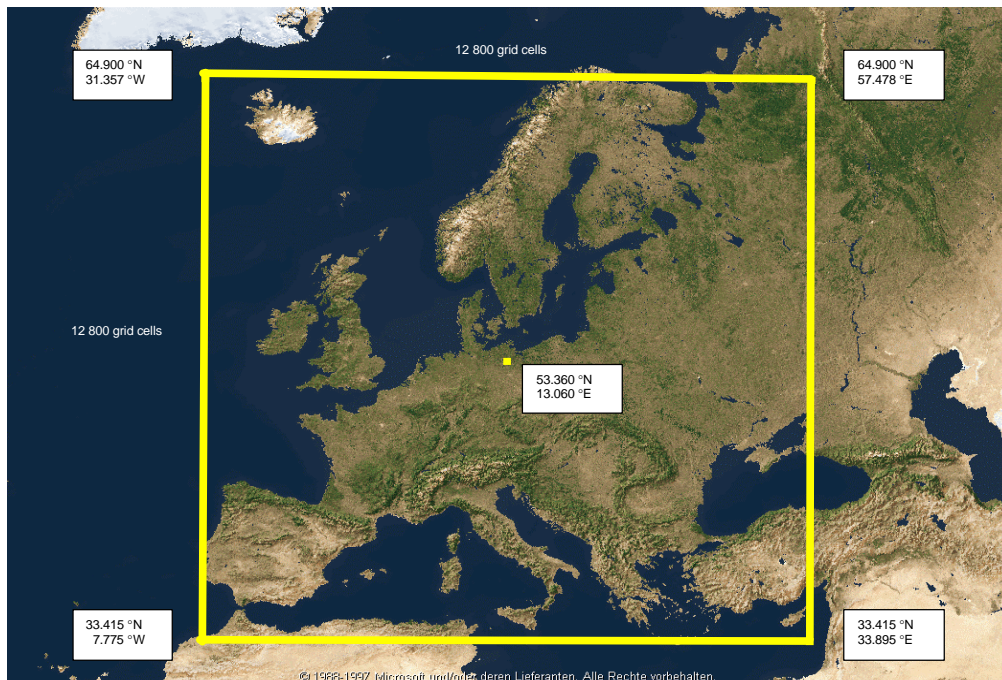

Figure 6 MERIS-VA Level 3 grid

4 ARCHITECTURE DESCRIPTION

4.1 Level 2 Data

4.1.1 Architectural breakdown

The top level breakdown of the MERIS Level 1 Architecture is represented schematically in figure Figure 7 below.

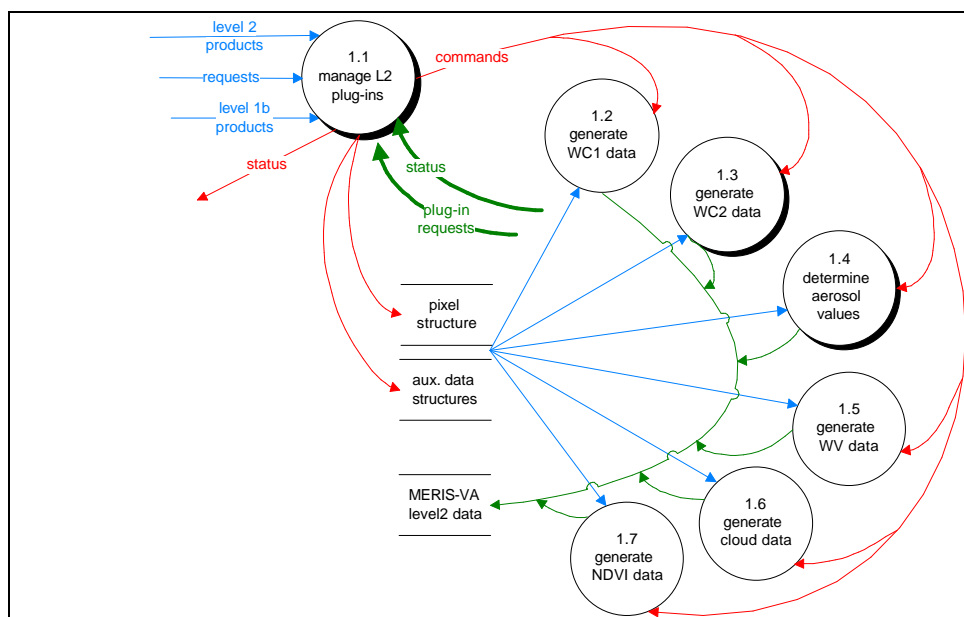

Figure 7 Generation of Level 2 Data

<h1 style="margin: 0;">MERIS</h1> <h2 style="margin: 0;">VA</h2>	Doc : Name :MERIS-VA System Architect. Theoretical Basis Document Issue : 1 Rev : 1 Date : 16.3.2000 Page : 14
--	--

Every module which generates a specific Level 2 product will be implemented following common rules concerning the interface and accessing the internal storages. They are called plug-ins. In this way, the list of level 2 product modules or plug-ins must not be fixed. The plug-ins are organized by a specific module, the Level 2 plug-in manager. This issues the commands to the plug-ins and organizes the data for them.

4.1.1.1 Detailed Description

The following sections provide, for each of the top level breakdown units shown above, a description of the unit's function, inputs, outputs.

4.1.1.1.1 Plug-In Management

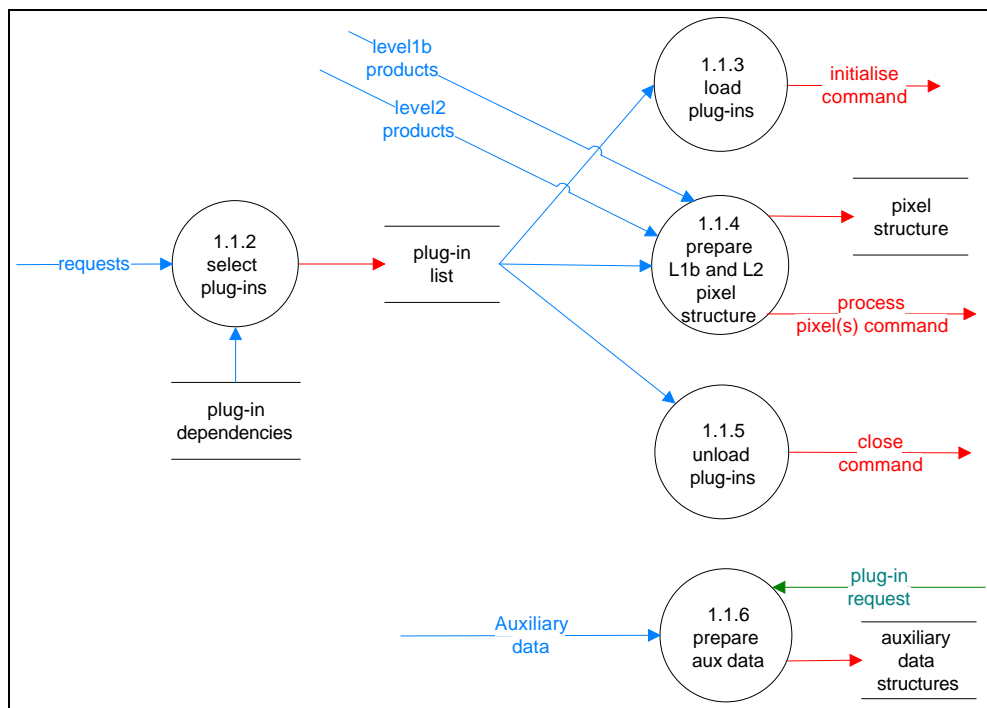

Figure 8 Level 2 Plug-In Management

A request includes the specification of which Level 2 products need to be generated. Based on this, the plug-in manager selects the required plug-ins, regarding the dependencies (i.e., if a specific plug-in needs another to be executed before, this one will also be included in the list of selected plug-ins even if it is not directly requested). These plug-in dependencies are maintained in an auxiliary data table “plug-in dependencies”.

The plug-in manager then has to load the plug-in, to prepare the Level 1b and Level 2 data into a pixel structure internal storage and issue the commands to generated the VA Level 2 product for that pixel structure. In this sense, the plug-in manager loops through the whole image while the plug-in works only on the pixel structure (which can have any number of individual pixels. This depends on the one hand on the requirements of the plug-ins, e.g. window processes, on the other on performance requirements).

Finally, the plug-in manager has to unload the plug-in.

<h1 style="margin: 0;">MERIS</h1> <h2 style="margin: 0;">VA</h2>	Doc : Name :MERIS-VA System Architect. Theoretical Basis Document Issue : 1 Rev : 1 Date : 16.3.2000 Page : 15
--	--

Details on implementing the plug-in concept under UNIX and on the memory management for large files are given in the appendices to this SATBD.

Algorithm Assessment

Criticality	LOW	MEDIUM	HIGH
Algorithm complexity	SIMPLE	MEDIUM	COMPLEX
Maturity / stability	OPERATIONAL	SEMI OPERATIONAL	RESEARCH
Interface	SIMPLE	MEDIUM	COMPLEX

4.1.1.1.2 Water Constituents 1

The generation of total suspended matter, yellow substance and chlorophyll concentration using the Neural Network approximated Inverse Modelling Technique is shown in Figure 9. It refers to ATBD 2.

There are two different products foreseen for that application. One consists of a Java application together with the Level 2 standard product (water leaving radiance reflectances). This is totally generated in the formatting module because it requires no data processing but only binding of existing code and data. The second application is described here.

Different neural nets are available for different geographical and temporal conditions (e.g. spring in the North Sea). Depending on the actual time and geography, which is included in the pixel structure, the proper Neural Net is selected and executed. The resulting concentrations of water constituents are checked for possible errors before stored in the main Level 2 product storage.

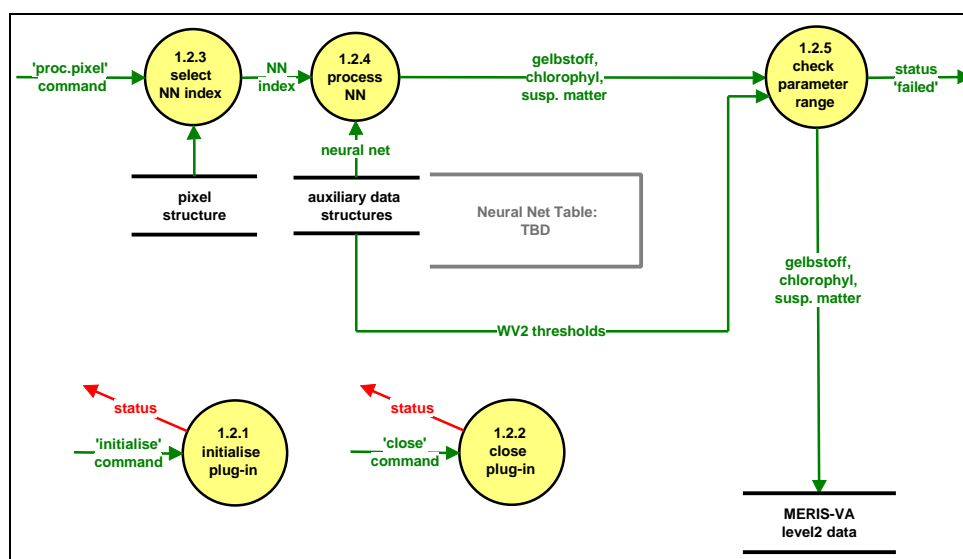

Figure 9 Water Constituents 1 (NN Method)

The neural nets will be stored in a tabulated format following the ESA Neural Net format.

<h1>MERIS</h1> <h2>VA</h2>	Doc Name : MERIS-VA System Architect. Theoretical Basis Document Issue : 1 Rev : 1 Date : 16.3.2000 Page : 16
----------------------------	---

Algorithm Assessment

Criticality	LOW	MEDIUM	HIGH
Algorithm complexity	SIMPLE	MEDIUM	COMPLEX
Maturity / stability	OPERATIONAL	SEMI OPERATIONAL	RESEARCH
Interface	SIMPLE	MEDIUM	COMPLEX

4.1.1.1.3 Water Constituents 2

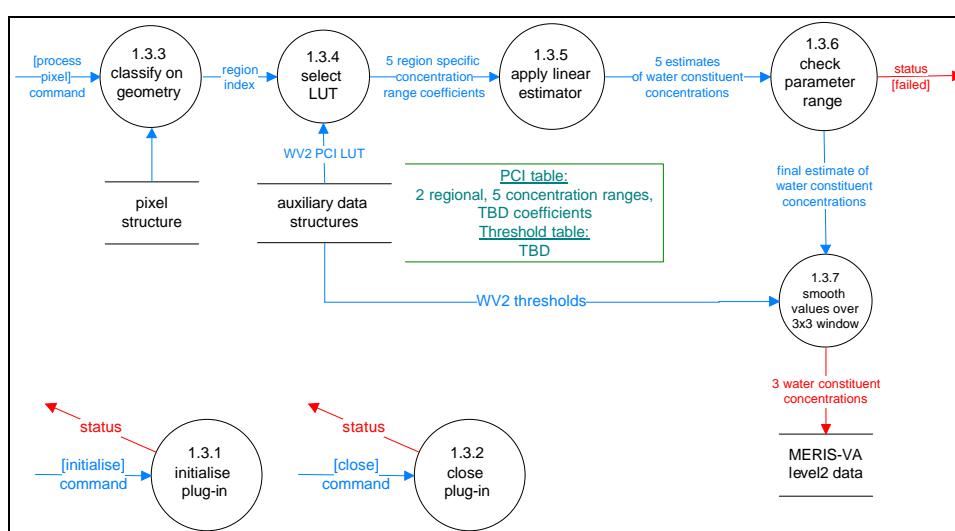

Figure 10 Calculation of water constituents 2 (PCI method)

The derivation of the concentration of water constituents with the PCI method is shown in Figure 10 and refers to ATBD 3. Basis for the method are tables including the parameters of the PCI regression formular (linear estimator). These are stored in an auxiliary data table, and the proper tables are selected based on geometry information. The linear estimates are derived for 5 different concentration ranges, and the correct one is selected based on the results of the estimates. Finally the values are smoothed over sliding window.

Algorithm Assessment

Criticality	LOW	MEDIUM	HIGH
Algorithm complexity	SIMPLE	MEDIUM	COMPLEX
Maturity / stability	OPERATIONAL	SEMI OPERATIONAL	RESEARCH
Interface	SIMPLE	MEDIUM	COMPLEX

4.1.1.1.4 Aerosol Properties

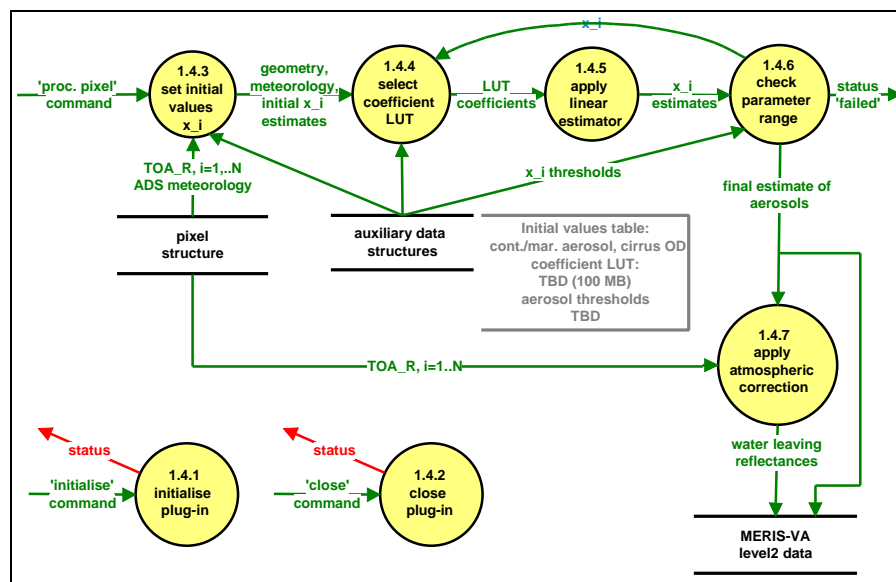

Figure 11 Calculation of aerosol properties

The generation of Aerosol properties is shown in Figure 11 and refers to ATBD 4. The method is based on a linear estimate of the aerosol properties from Level 1b measurements. Additionally, the water leaving radiance reflectance is derived as an internal product.

The parameters for the linear estimation are read from an auxiliary data table, and the proper coefficients are selected according to geometry and meteorological conditions, which are available in the pixel structure. Also, initial values for the aerosol properties have to be assigned. If these are not available from a previous pixel, they have to be read from auxiliary data.

Algorithm Assessment

Criticality	LOW	MEDIUM	HIGH
Algorithm complexity	SIMPLE	MEDIUM	COMPLEX
Maturity / stability	OPERATIONAL	SEMI OPERATIONAL	RESEARCH
Interface	SIMPLE	MEDIUM	COMPLEX

4.1.1.1.5 Water Vapour

The water vapour calculation is shown below in Figure 12 and refers to MAPP-ATBD-WV. The water vapour will be retrieved with a trained neural net. The parameters for the net are read from an auxiliary data table.

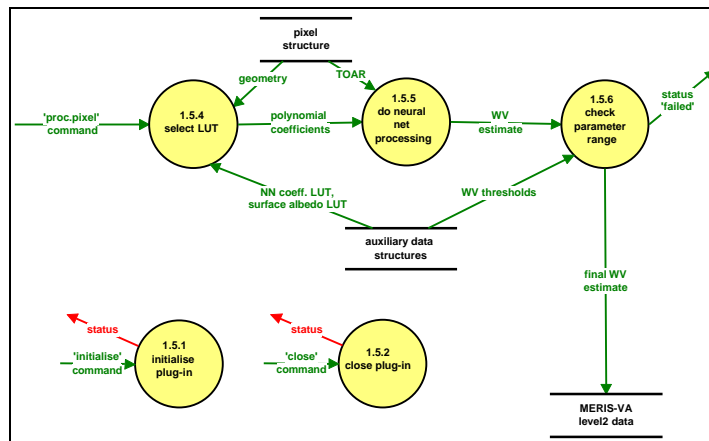

Figure 12 Calculation of water vapour

Algorithm Assessment

Criticality	LOW	MEDIUM	HIGH
Algorithm complexity	SIMPLE	MEDIUM	COMPLEX
Maturity / stability	OPERATIONAL	SEMI OPERATIONAL	RESEARCH
Interface	SIMPLE	MEDIUM	COMPLEX

4.1.1.1.6 Cloud Products

The cloud products include cloud optical thickness, cloud albedo and cloud top height. Their generation is shown in Figure 12. They are described in MAPP-ATBD-CACO and MAPP-ATBD-CTP.

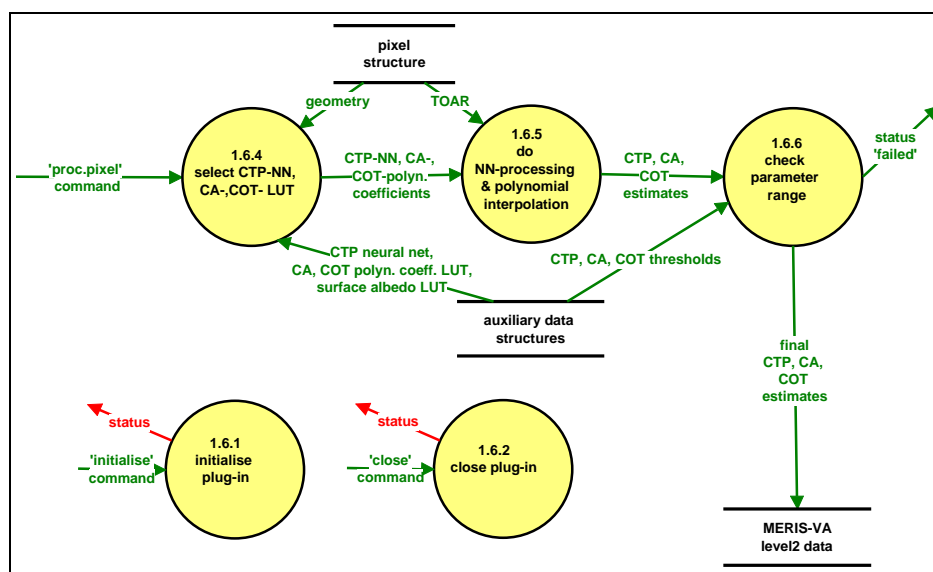

Figure 13 Calculation of cloud products

The generation of cloud albedo and cloud optical thickness uses polynomial expressions, while the cloud top height is calculated by a neural net. However, all algorithms require coefficients,

<h1 style="margin: 0;">MERIS</h1> <h1 style="margin: 0;">VA</h1>	Doc : Name :MERIS-VA System Architect. Theoretical Basis Document Issue : 1 Rev : 1 Date : 16.3.2000 Page : 19
--	--

which are either the polynomial coefficients or a tabulated neural net. These are retrieved based on geometry. Also, the surface albedo is required by the algorithms.

Algorithm Assessment

Criticality	LOW	MEDIUM	HIGH
Algorithm complexity	SIMPLE	MEDIUM	COMPLEX
Maturity / stability	OPERATIONAL	SEMI OPERATIONAL	RESEARCH
Interface	SIMPLE	MEDIUM	COMPLEX

4.1.1.1.7 NDVI

The retrieval of the NDVI is a simple procedure which interpolates the channels of the AVHRR from proper MERIS Level 1b data and computes the NDVI.

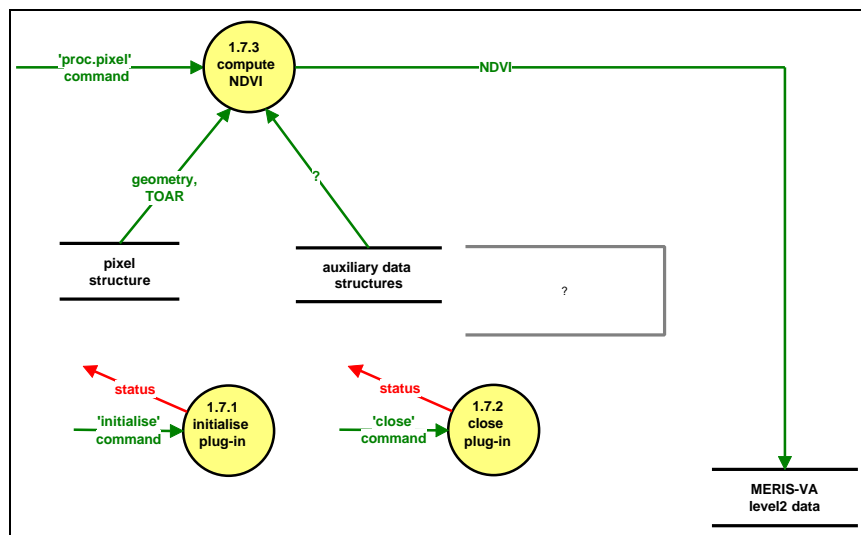

Figure 14 Calculation of NDVI

Algorithm Assessment

Criticality	LOW	MEDIUM	HIGH
Algorithm complexity	SIMPLE	MEDIUM	COMPLEX
Maturity / stability	OPERATIONAL	SEMI OPERATIONAL	RESEARCH
Interface	SIMPLE	MEDIUM	COMPLEX

<h1>MERIS</h1> <h2>VA</h2>	Doc : Name :MERIS-VA System Architect. Theoretical Basis Document Issue : 1 Rev : 1 Date : 16.3.2000 Page : 20
----------------------------	--

4.2 Level 3 Data

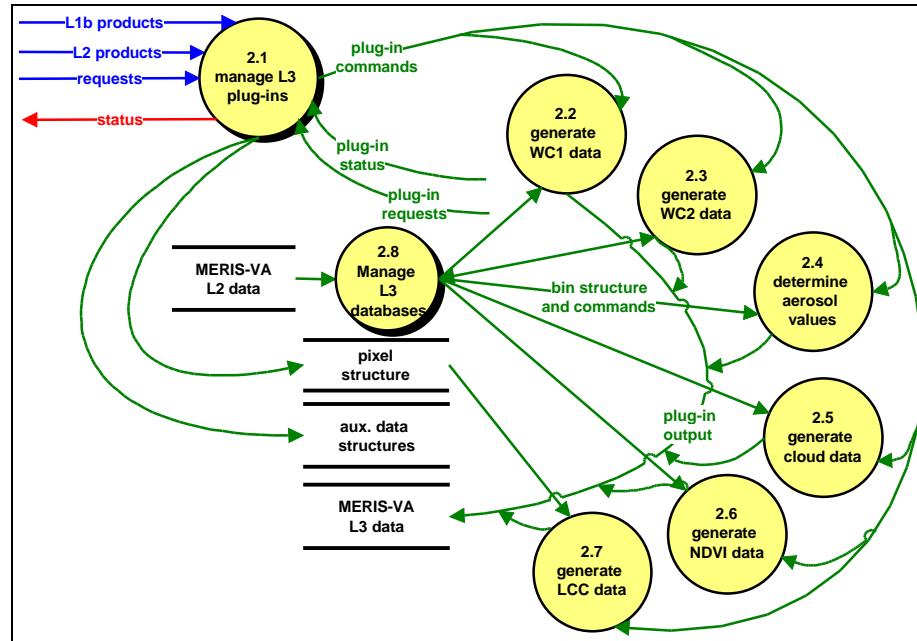

Figure 15 Level 3 product generation

The generation of the Level 3 data implements the same plug-in concept as the generation of the Level 2 data. The individual Level 3 modules have a common interface structure and are initiated and managed by the plug-in manager. The latter acts in the same way as the Level 2 plug-in manager but is supported by the Level 3 database manager, which maintains the three main data storages: the pixel structure which contains the set of pixels to be processed, a storage for auxiliary data, e.g. polynomial coefficients, and the Level 3 product storage.

4.2.1 Level 3 plug-in management

A request includes the specification of which Level 3 products need to be generated. Based on this, the plug-in manager selects the required plug-ins, regarding the dependencies (i.e., if a specific plug-in needs another to be executed before, this one will also be included in the list of selected plug-ins even if it is not directly requested). These plug-in dependencies are maintained in an auxiliary data table “plug-in dependencies”.

The plug-in manager then has to load the plug-in, to prepare the Level 1b and Level 2 data into a pixel structure internal storage and issue the commands to generated the VA Level 3 product for that pixel structure. In this sense, the plug-in manager loops through the whole image while the plug-in works only on the pixel structure (which can have any number of individual pixels. This depends on the one hand on the requirements of the plug-ins, e.g. window processes, on the other on performance requirements).

Finally, the plug-in manager has to unload the plug-in.

Details on implementing the plug-in concept under UNIX and on the memory management for large files are given in the appendices to this SATBD.

<h1 style="margin: 0;">MERIS</h1> <h2 style="margin: 0;">VA</h2>	Doc : Name :MERIS-VA System Architect. Theoretical Basis Document Issue : 1 Rev : 1 Date : 16.3.2000 Page : 21
--	--

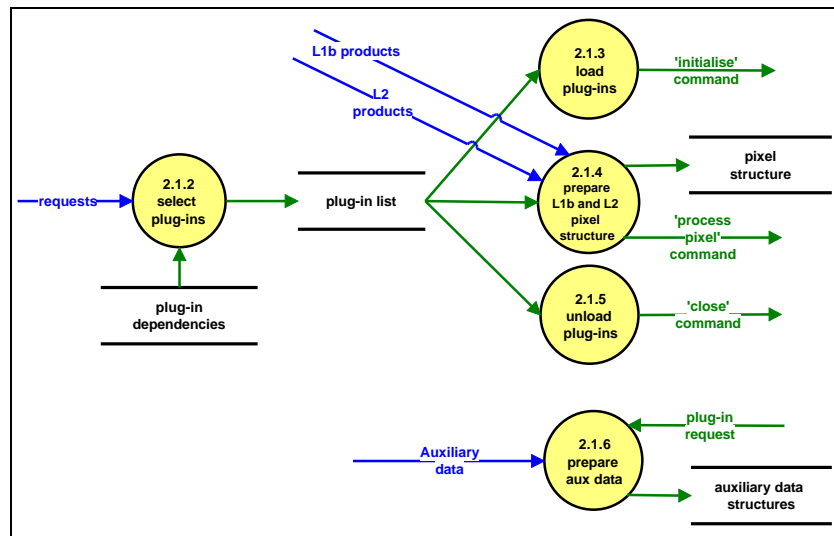

Figure 16 Level 3 Plug-In management

Algorithm Assessment

Criticality	LOW	MEDIUM	HIGH
Algorithm complexity	SIMPLE	MEDIUM	COMPLEX
Maturity / stability	OPERATIONAL	SEMI OPERATIONAL	RESEARCH
Interface	SIMPLE	MEDIUM	COMPLEX

4.2.2 Level 3 database management

While the Level 2 processes work only on simple pixel structures, which is a set of 1 or more samples together with all relevant information for that pixel (geometry, location, ...), the data structure for the Level 3 processes are more complex and must be regarded together with the operations performed on it. The mathematical background is described in MAPP-ATBD-GENL3.

The generation of the generic Level 3 products includes the binning into the MAPP-Level 3 grid (Mn grid) and the spatial and temporal integration of the corresponding data following the procedure described in MAPP-ATBD-GENL3. This is shown schematically in Figure 17. The spatial processing includes the computation of the bin index i from the geographical location of a given pixel. The logarithm and the squares of the logarithms of the parameters of concern of all pixels belonging to a bin are summed up ($S1_i$ and $S2_i$ matrix). Further, for every bin (still for one overpass), the number of samples per bin (n_i matrix) is stored.

<h1 style="margin: 0;">MERIS</h1> <h2 style="margin: 0;">VA</h2>	Doc : Name :MERIS-VA System Architect. Theoretical Basis Document Issue : 1 Rev : 1 Date : 16.3.2000 Page : 22
--	--

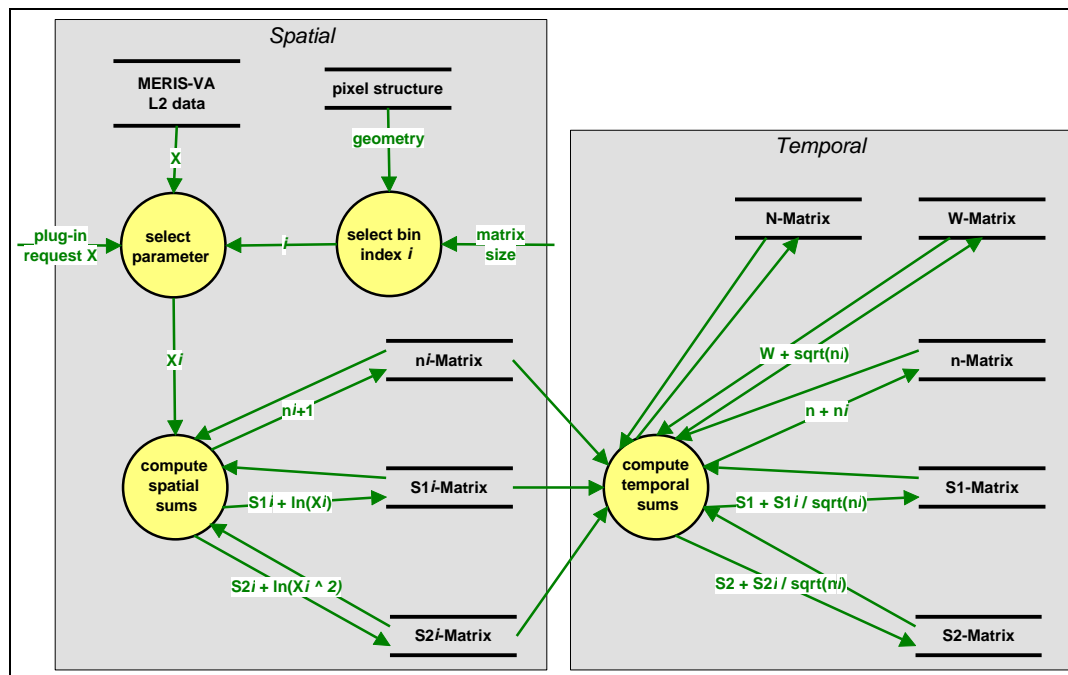

Figure 17 Level 3 database management

The temporal integration then computes temporal sums for every bin using the chosen weighting: the N-matrix contains the total number of samples, the W-matrix the sum of the weights (in Figure 17 the weights are the inverse root of number of samples), the n-matrix the number of samples per bin and the S1 and S2 matrices the weighted sums of the individual sum and squares matrices.

Algorithm Assessment

Criticality	LOW	MEDIUM	HIGH
Algorithm complexity	SIMPLE	MEDIUM	COMPLEX
Maturity / stability	OPERATIONAL	SEMI OPERATIONAL	RESEARCH
Interface	SIMPLE	MEDIUM	COMPLEX

4.3 Generation of generic Level 3 products

The so called “generic” Level 3 products are those, which are a direct spatial and temporal integration of the corresponding Level 2 products, and for which the procedures are already implemented in the Level 3 database management.

At present, these products are the Water Constituents 1 and 2, the aerosol properties and the NDVI. These modules only need to define the temporal and spatial integration parameters for the database management module.

Algorithm Assessment

Criticality	LOW	MEDIUM	HIGH
-------------	-----	--------	------

<h1 style="margin: 0;">MERIS</h1> <h2 style="margin: 0;">VA</h2>	Doc : Name :MERIS-VA System Architect. Theoretical Basis Document Issue : 1 Rev : 1 Date : 16.3.2000 Page : 23
--	--

Algorithm complexity	SIMPLE	MEDIUM	COMPLEX
Maturity / stability	OPERATIONAL	SEMI OPERATIONAL	RESEARCH
Interface	SIMPLE	MEDIUM	COMPLEX

4.4 Generation of Level 3 cloud and Water Vapour products

The Level 3 cloud and water vapour products are derived statistical products which differ from their corresponding Level 2 products. In an ISCCP compatible way, the fractional cloud cover, the cloud top pressure, cloud optical depth and water vapour content are calculated. The data will be stored in a M16 grid, but the mathematics to fill the data table differs from the generic method, so that an own database handling will be used.

Algorithm Assessment

Criticality	LOW	MEDIUM	HIGH
Algorithm complexity	SIMPLE	MEDIUM	COMPLEX
Maturity / stability	OPERATIONAL	SEMI OPERATIONAL	RESEARCH
Interface	SIMPLE	MEDIUM	COMPLEX

4.5 Generation of LCC

The LCC is a product which has no direct corresponding Level 2 product, It is directly generated from MERIS L2 surface reflectances. The processing includes three steps:

1. A classification of every pixel of an overflight. The classification result is binned and stored for step 2.
2. A multitemporal, monthly analysis of the stored overflight values (monthly LCC).
3. A multitemporal, yearly analysis of the monthly LCC.

In the first step, the geolocation values of the pixel structure are used to select the spectral signature covariance matrix from an auxiliary data table, which is used in the maximum likelihood classification. This assigned a class number to every pixel.

In the second step, after the period of one month, for every bin the most and second most frequent class number are selected as the resulting classes for that month and stored as monthly LCC.

In the third step, the series of 12 monthly mean NDVI values for a given bin are compared with typical NDVI time series of the 17 classes used for the final classification. This time signal is an additional information, which is used together with the 12 monthly classes in order to determine the final class for that bin. This gives the yearly LCC class.

	MERIS VA	Doc : Name :MERIS-VA System Architect. Theoretical Basis Document Issue : 1 Rev : 1 Date : 16.3.2000 Page : 24
--	-------------------------------	--

Algorithm Assessment

Criticality	LOW	MEDIUM	HIGH
Algorithm complexity	SIMPLE	MEDIUM	COMPLEX
Maturity / stability	OPERATIONAL	SEMI OPERATIONAL	RESEARCH
Interface	SIMPLE	MEDIUM	COMPLEX

<h1 style="margin: 0;">MERIS</h1> <h2 style="margin: 0;">VA</h2>	Doc : Name :MERIS-VA System Architect. Theoretical Basis Document Issue : 1 Rev : 1 Date : 16.3.2000 Page : 25
--	--

5 LEVEL 2 ADD (DRAFT)

5.1 Use Cases

Three actors have been identified:

- 1) The main actor is the Processing System Management (PSM). This software generates the operational and recurring processing requests and controls the MERIS-VA processor.
- 2) An operator, which is a real person and who is responsible for the processor.
- 3) A validator who performs off-line quality control.

These actors perform the following use cases with respect to the processor (see Figure 1):

The operator maintains the processor which includes mainly the installation of new Plug-Ins. Then, he controls the processing, which the generation of the various product types of the processor in exceptional cases, e.g. during campaigns or for a re-processing. Finally, he inspects and verifies each processing job for its correct performance.

In addition to this verification, a more intensive validation is done by the validator. This is a scientific assessment of the quality of the products. For this, it should be able to generate intermediate variables of the processing.

The generation of the Level 2, Level 3 and User products are the main use cases. During normal operations, these include the whole processing chain from the ESA Level 1b and 2 to the MERIS-VA products.

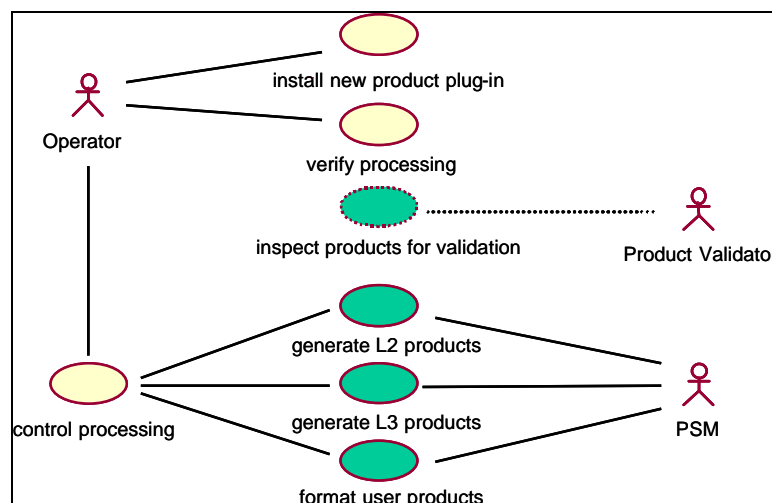

Figure 1: Use Cases for the MERIS-VA Processor

These use cases are reflected in the architecture as individual sub-processors, which have a common interface to the PSM. This is reflected in Figure 2, which shows the co-operation between DIMS/Product Library, the processing system, which includes the PSM and the MERIS-VA processor, and the operator through an operating tool.

<h1>MERIS</h1> <h2>VA</h2>	Doc : Name :MERIS-VA System Architect. Theoretical Basis Document Issue : 1 Rev : 1 Date : 16.3.2000 Page : 26
----------------------------	--

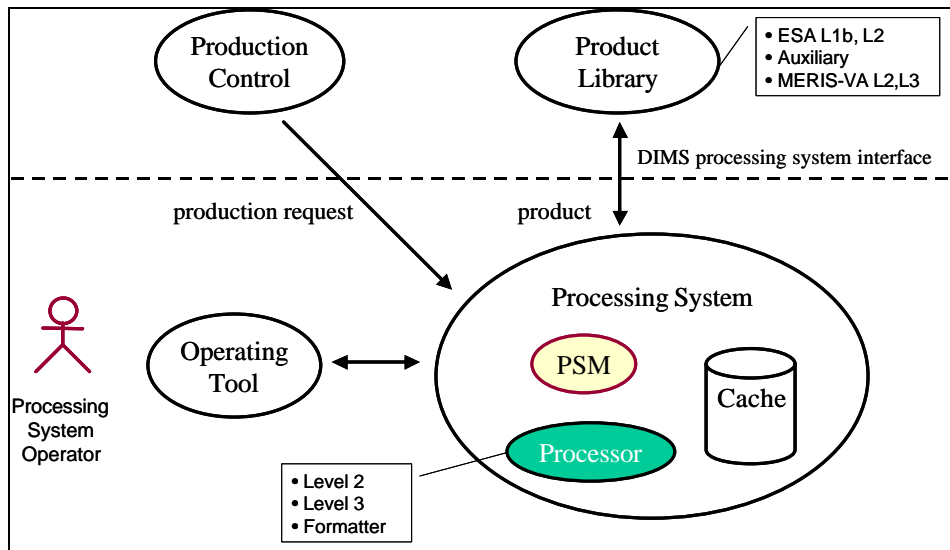

Figure 2: Co-operation between DIMS and processing system.

DIMS has the overall control. Production requests are submitted by the production control to the PSM. This retrieves the required input and auxiliary products from the product library and puts it into a cache space, which is connected with the processor. The PSM then invokes the processor. This is detailed in Figure 3.

The PSM initialises the MERIS-VA processor body. This reads its configuration from a file (cfg), which includes – among others – the available Plug-Ins. After successful initialisation, which is reported back to the PSM, this starts the processor with the details of the processing requests, i.e. the requested products and its parameters. The processor reads the necessary parameters, e.g. coefficients for Plug-Ins, and the Input products from the cache space. During generation of the products, the processor may submit status information to the PSM, and this suspend or revoke the processor. Finally, when the output products have been written, the processor reports its completion to the PSM, which gives the output products to the product library (not shown here) and terminates the processor.

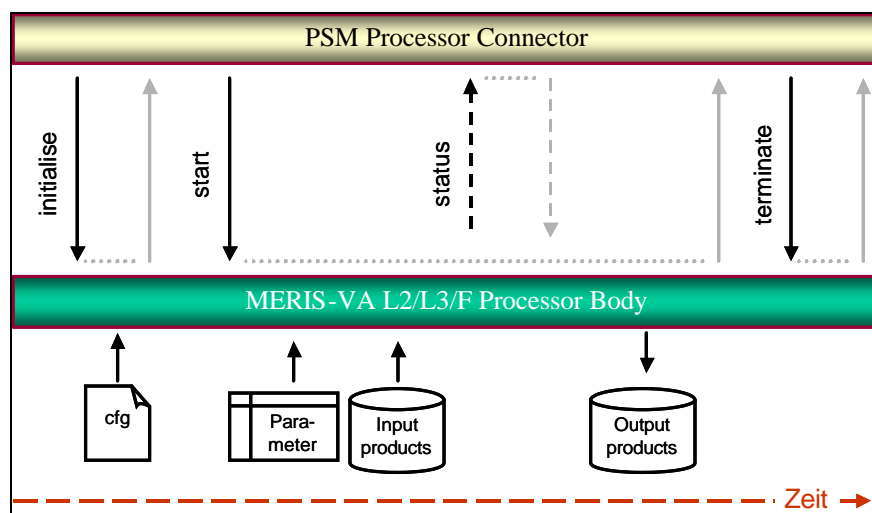

Figure 3: Communication between PSM and processor body for a processing request.

<h1>MERIS</h1> <h2>VA</h2>	Doc : Name :MERIS-VA System Architect. Theoretical Basis Document Issue : 1 Rev : 1 Date : 16.3.2000 Page : 27
----------------------------	--

5.2 Logical Structure

The MERIS-VA processor has a top-level structure which reflects the use cases (see Figure 4). In three packages are the sub-processors for the generation of Level 2 (meris_va_l2), Level 3 (meris_va_l3) and User Product Formatting (meris_va_f) organised. These depend on reusable basis classes, which are grouped in the two packages for basic MERIS-VA classes (meris_va_base) and the standard Brockmann Consult Classes (bc_std). This includes mainly existing basic functionality. E.g., it depends on the commercially available Tera-Scan API, the public domain hdf API and the neural net classes of BC.

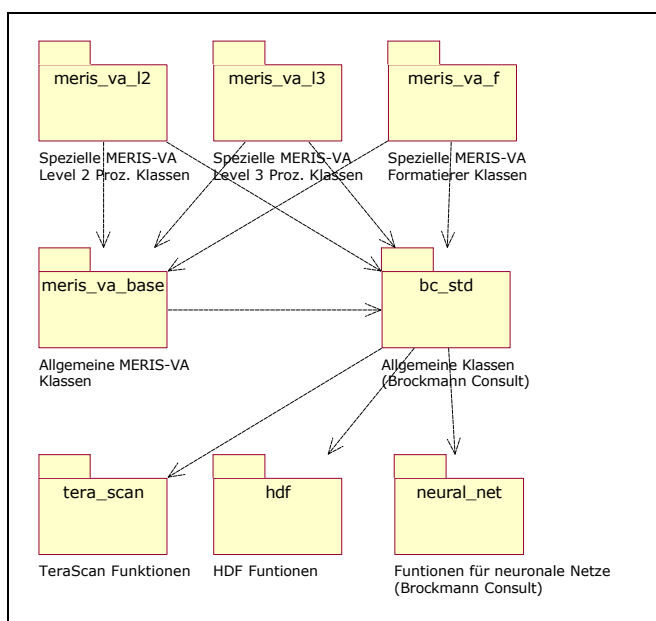

Figure 4: Package structure of the MERIS-VA processor

5.3 Physical Structure

The external interface of the MERIS-VA is the DIMS connection layer. This has been established by DFD in form of the PSM. This layer handles the processing requests and the interfacing with the product library.

The three top level packages of the logical structure are reflected in corresponding APIs. This means, that the PSM can call each of the subprocessors individually. By this, the individuality of the use cases is correctly implemented. The Plug-Ins are also separate elements which interface with the Level 2 and Level 3 sub-processors. It becomes clear here that the sub-processor and the Plug-Ins are individual and separate elements, and the sub-processors call the Plug-Ins (and vice versa) if demanded.

The MERIS-VA base layer is a combination of the Base API, which implements the meris_va_base package, and the BC-STD API. This interfaces directly with the processor body layer and also with the Base API. Finally, off-the-shelf software is used where possible (COTS layer).

<h1 style="margin: 0;">MERIS</h1> <h1 style="margin: 0;">VA</h1>	Doc : Name :MERIS-VA System Architect. Theoretical Basis Document Issue : 1 Rev : 1 Date : 16.3.2000 Page : 28
--	--

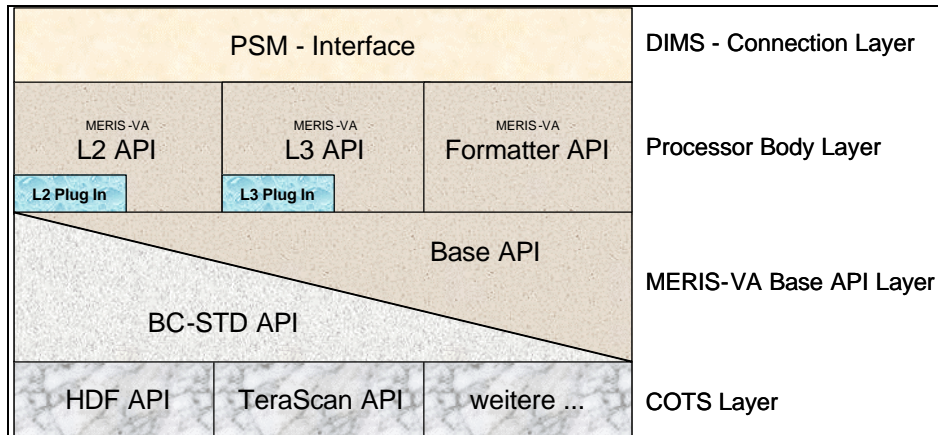

Figure 5: Physical Layers of the processor software

5.4 Architecture Details

The model for the Processor-Class is shown in Figure 6. This is the basic class from which the L2 Processor, L3Processor and Formatter Classes are derived. It processes a ProductionRequest, which is the connection to the PSM.

A Processor has one PlugInManager, which is detailed in Figure 7. He has the responsibility to create an ActivePlugInList, which is the list of those PlugIns, which are required to fulfil the production request. In order to create this list, the PlugInManager has to get the PlugInDescriptors for all requested products and those, which depend on already required PlugIns (Dependency Class of the PlugInDescriptor). With this list and the corresponding PlugInDescriptors, the PlugInManager can then call the Plug-Ins, which itself only need to process a Pixel or a set of Pixels, a so called Granule.

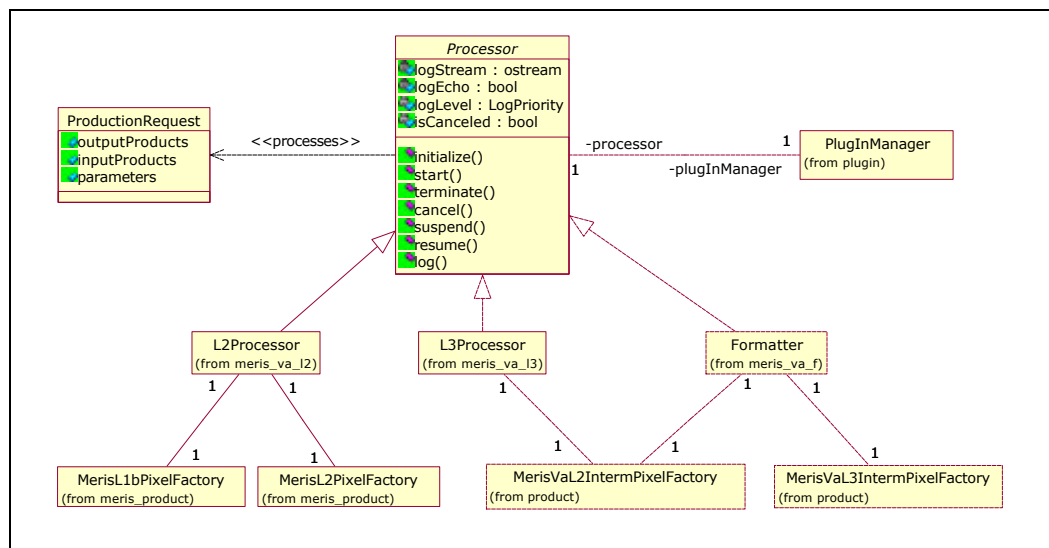

Figure 6: The Processor Class

<h1 style="margin: 0;">MERIS</h1> <h1 style="margin: 0;">VA</h1>	<p>Doc Name : MERIS-VA System Architectural Theoretical Basis Document</p> <p>Issue : 1 Rev : 1</p> <p>Date : 16.3.2000</p> <p>Page : 29</p>
--	--

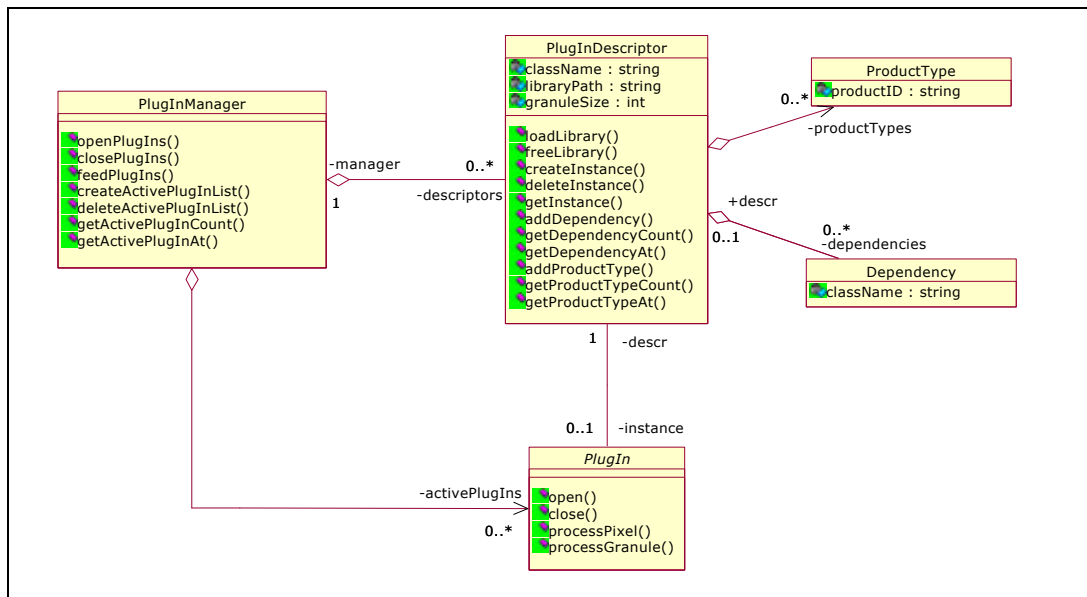

Figure 7: The Plug-In Classes

The pixel (or granule) needs to be prepared before it can be given to a Plug-In. The concerned classes are shown in Figure 8 and Figure 9. The MerisPixelFactory is the basis class for MERISL1bPixelFactory and MERISL2PixelFactory, which are associated with the Processor (see Figure 6).

The MerisPixelFactory is a MerisProductReader, because the MERIS Products have a structure which makes it possible to deduce generalised methods. The MerisPixelFactory basically is responsible to sample all the pixel relevant information from the different locations in the MERIS product files (e.g. GADS – Global Annotation Data Set, LADS – Location Annotation Data Sets, which are better known as Tie-Point annotations), and to associate them with every pixel correctly. This includes of course the interpolation of the LADS data to pixel resolution.

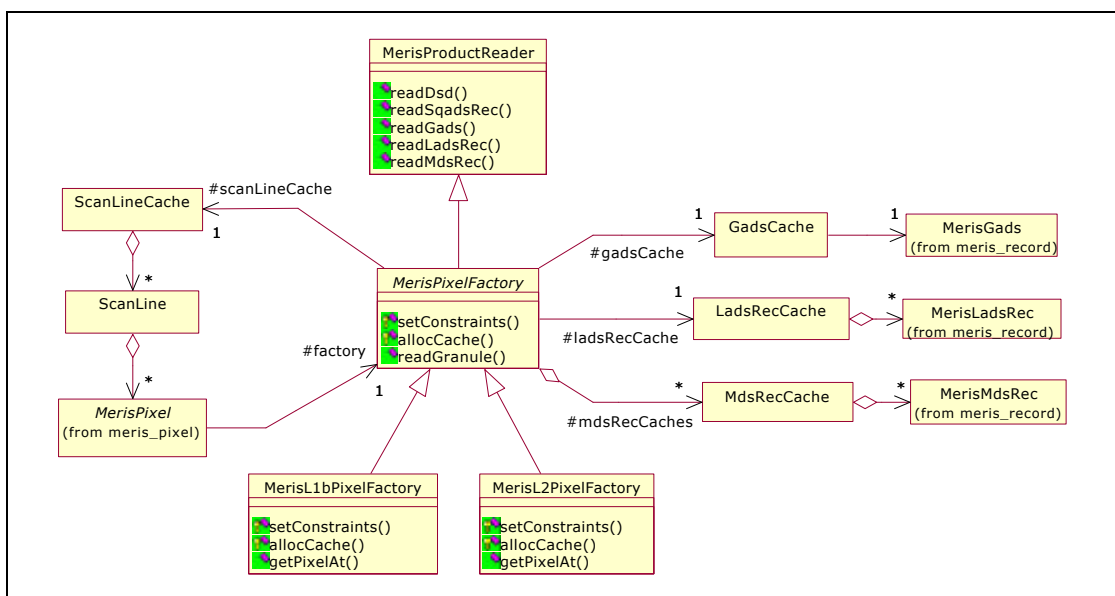

Figure 8: The MERIS Pixel Factory

	<h1 style="margin: 0;">MERIS</h1> <h2 style="margin: 0;">VA</h2>	Doc : Name :MERIS-VA System Architect. Theoretical Basis Document Issue : 1 Rev : 1 Date : 16.3.2000 Page : 30
--	--	--

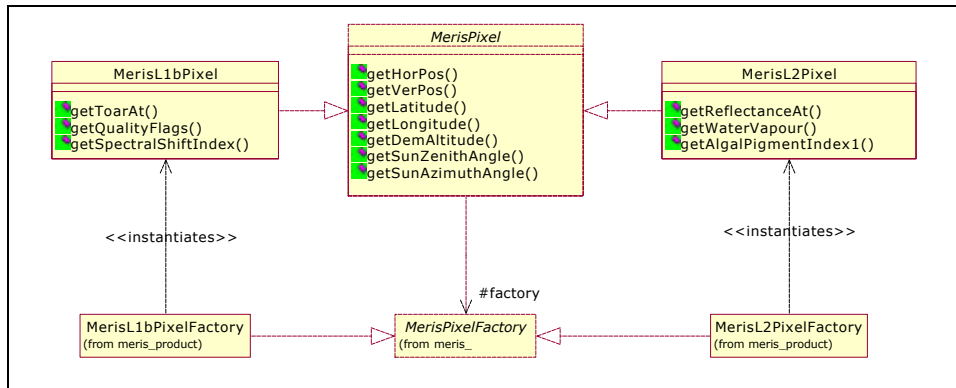

Figure 9: The MERIS Pixel Class

So, finally, a MERISPixel class has methods to provide all relevant information common to Level 1 and 2 products, which are its position in the image and in geographical coordinates, its sun and viewing geometry etc. The deduced MerisL1bPixel and MerisLevel2Pixel classes have, additionally, methods to provide the specific values, i.e. the spectral radiances or geophysical parameters.

Consequently, a Plug-In is supplied with a Pixel, which knows everything about itself.

	MERIS VA	Doc : Name :MERIS-VA System Architect. Theoretical Basis Document Issue : 1 Rev : 1 Date : 16.3.2000 Page : 31
--	-------------------------------	--

6 APPENDIX

6.1 Computational Resource Document

	MERIS VA	Doc : Name :MERIS-VA System Architect. Theoretical Basis Document Issue : 1 Rev : 1 Date : 16.3.2000 Page : 32
--	-------------------------------	--

Titel: **MERIS-VA Computational Resource Requirements**
Document

Project: MAPP

Doc. No.: TN-MAPP-CB-CRR

Issue: draft

Revision:

Date: 20.5.1999

	<u>Function</u>	<u>Name</u>	<u>Organisation</u>	<u>Signature</u>	<u>Date</u>
Author:		Carsten Brockmann	Brockmann Consult		
		Norman Fomferra	Brockmann Consult		

<h1>MERIS</h1> <h2>VA</h2>	Doc : Name :MERIS-VA System Architect. Theoretical Basis Document Issue : 1 Rev : 1 Date : 16.3.2000 Page : 33
----------------------------	--

6.1.1 Scope of the document

This document defines the hard- and software requirements for the MERIS-VA processor. The document will evolve in the same way as the algorithm definitions and the system architecture change.

6.1.2 Applicable Documents

AD1 MAPP Algorithm Theoretical Basis Document. MAPP ATBD 1.0, 8.3.1999

6.1.3 disk space requirements

6.1.3.1 MERIS-VA Products Overview

The MERIS-VA processor generates Level 2 and Level 3 products. The Level 3 products require the corresponding Level 2 products. Therefore, each received orbit must be processed up to Level 2, and some intermediate products (integrators for the Level 3 products) must be generated.

The Level 2 data and Level 3 integrators are stored in an internal format, which is optimised for processing efficiency. When products are requested by a user (which is regularly for final Level 3 products, but irregularly for Level 2 products), the formatting module of the processor generates the requested area and time from the internal format. Therefore, the Level 2 and 3 products must be permanently stored in the internal format.

The processor requires for the processing of a single orbit the Level 1b and Level 2 data of the ESA MERIS processor, and the integrators for the Level 3 products. During the processing, the Level 2 intermediate products must also be stored locally. After processing, the Level 2 products and the integrators must be stored in the DIMS products library.

6.1.3.2 Input Products

Input to the processor are the ESA MERIS Level 1b and Level 2 products. The characteristics of these are specified in Table 1. A complete orbit is divided into 84 scenes because of the product specifications of the ESA processor. Each MERIS line has 4484 samples, while a product includes only 1940 samples, so that 3 products are necessary to reproduce a full swath. An orbit includes approximately 59200 scan lines, but a product includes only 2200 lines. Consequently, 28 products are required to build the length of an orbit. In total this yields $3 \times 28 = 84$ ESA products for 1 orbit.

The total disk space requirement for the input data for 1 orbit is 7.5 Gbyte.

	ESA Produkt					
Level	Width	Height	Samples	Lines	size / MB	Products
L1b	582 km	650 km	1940	2200	41	1
L2	582 km	650 km	1940	2200	50	1
	Orbit					
L1b	1345 km	17760 km	4484	59200	3444	$3 \times 28 = 84$
L2	1345 km	17760 km	4484	59200	4200	84
Sum Orbit					7644	

Table 1: Product specifications of the ESA MERIS Level 1b and 2 products.

<h1>MERIS</h1> <h2>VA</h2>	Doc : Name :MERIS-VA System Architect. Theoretical Basis Document Issue : 1 Rev : 1 Date : 16.3.2000 Page : 34
----------------------------	--

6.1.3.3 Level 2 intermediate products

In the worst case, every Level 2 product is generated for every pixel of an orbit, and it is stored in a plain binary array of a floating point variable. The resulting requirements for disk space is specified in Table 2.

The disk space requirements for the Level 2 intermediate products will not exceed 16.8 Gbyte.

<i>Parameter</i>	<i>Produkt</i>	<i>Pixel (max)</i>	<i>Größe max, 4 Byte / pixel</i>	
Chlorophyll Konzentration Nordsee	WC1	265.452.800	1012,62207	MB
Schwefstoffkonzentration Nordsee	WC1	265.452.800	1012,62207	MB
Gelbstoff Nordsee	WC1	265.452.800	1012,62207	MB
Chlorophyll Konzentration Ostsee	WC2	265.452.800	1012,62207	MB
Schwefstoffkonzentration Ostsee	WC2	265.452.800	1012,62207	MB
Gelbstoff Ostsee	WC2	265.452.800	1012,62207	MB
Optische Tiefe Aerosol	AER	265.452.800	1012,62207	MB
Mischungsverhältnis Aerosol	AER	265.452.800	1012,62207	MB
NDVI	NDVI	265.452.800	1012,62207	MB
Optische Tiefe Wolken	CO	265.452.800	1012,62207	MB
Albedo Wolken	CA	265.452.800	1012,62207	MB
Wolkenoberkantendruck	CTP	265.452.800	1012,62207	MB
Wasserdampf	WV	265.452.800	1012,62207	MB
LCC interm	LCC	265.452.800	1012,62207	MB
Geometry	GEO	265.452.800	1012,62207	MB
Auxiliary	AUX	265.452.800	1012,62207	MB
Flags	FLAG	265.452.800	1012,62207	MB
Summe			16,8	GB

Table 2: Disk space requirements of the Level 2 intermediate products in the worst case.

6.1.3.4 Level 3 intermediate products

M1 Matrix			
<i>samples</i>	<i>lines</i>	<i>cells</i>	<i>size / MB</i>
12800	12800	163 840 000	625
spatial statistic			
<i>Matrix</i>	<i>Byte/pixel</i>		<i>Größe / MB</i>
ni	1		156
S1i	4		625
S2i	4		625
Sum			1.406
temporal statistic			
<i>Matrix</i>	<i>Byte / pixel</i>		<i>Größe / MB</i>
N	2		313

	<h1 style="margin: 0;">MERIS</h1> <h2 style="margin: 0;">VA</h2>	Doc : Name :MERIS-VA System Architect. Theoretical Basis Document Issue : 1 Rev : 1 Date : 16.3.2000 Page : 35
--	--	--

n	2	313
W	4	625
S1	4	625
S2	4	625
Sum		2.500

Table 3: Basic data for the M1 grid.

Byte per Klassifikation	4	
Größe einer klassifizierten Szene	14	MB
Größe einer klassifizierten M1 Matrix	625	MB
Anzahl M1 Matrizen für monatliche Auswertung	32	31 Tage + Monatsmatrix
Größe des Speichers für monatlichen Auswertung	19,5	GB
Anzahl M1 Matrizen für Jahresauswertung	12	
Größe des Speichers für Jahresauswertung	7,3	GB
Maximale Speichergröße	19,5	GB

Table 4: Basic data for LCC processing.

<h1>MERIS</h1> <h2>VA</h2>	Doc : Name :MERIS-VA System Architect. Theoretical Basis Document Issue : 1 Rev : 1 Date : 16.3.2000 Page : 36
----------------------------	--

alle Parameter auf M16 Gitter, d.h. 640 000 pixel				
<i>ISCCP compatible product</i>				
Parameter	Bytes / bin	Anzahl	Größe / MB	
Nk	2	10	12	Number of observation in a cloud class k
CTPk	4	10	24	avarage CTP in class k
VAR_CTPk	4	10	24	variance CTP in class k
CODk	4	10	24	avarage COD in class k
VAR_CODk	4	10	24	variance COD in class k
Summe			110	
<i>high vertical resolution product</i>				
Nv	2	19	23	Number of observation in a vertical class v
CTPv	4	19	46	avarage CTP in class v
VAR_CTPv	4	19	46	variance CTP in class v
CODv	4	19	46	avarage COD in class v
VAR_CODv	4	19	46	variance COD in class v
WVPv	4	19	46	avarage WVP in class v
VAR_WVPv	4	19	46	variance WVP in class v
Summe			302	
Gesamtsumme WolkenWasserdampf			411	
Zeitliche Auflösung: Wochenmittel und Monatsmittel				
um die auszurechnen, braucht man jeden Parameter 2 mal				
Gesamtsumme für Wochen- und Monatsmittel			823	

<h1>MERIS</h1> <h2>VA</h2>	Doc : Name :MERIS-VA System Architect. Theoretical Basis Document Issue : 1 Rev : 1 Date : 16.3.2000 Page : 37
----------------------------	--

<i>Parameter</i>	<i>Produkt</i>	<i>temporär</i>	<i>permanent</i>	
Chlorophyll Nord/Ostsee	WC	1.406	5.000	MB
Schwebstoff Nord/Ostsee	WC	1.406	5.000	MB
Gelbstoff Nord/Ostsee	WC	1.406	5.000	MB
Optische Tiefe Aerosol	AER	1.406	5.000	MB
Mischungsverhältnis Aerosol	AER	1.406	5.000	MB
NDVI	NDVI	1.406	5.000	MB
LCC	LCC		20.000	MB
WolkenWasserdampf	ATM		823	MB
Summe		8	50	GB

Table 5: Disk space requirements for the intermediate Level 3 products in the worst case.

6.1.3.5 User products

Not defined at present.

6.1.3.6 Summary

<i>Gruppe</i>	<i>GB</i>
ESA input	7,5
MAPP Level 2	16,8
MAPP Level 3	57,9
Prozessor Tabellen	2,0
Virtueller Speicher	2,0
Prozessor Software	1,0
Summe	87,1

Table 6: Estimate of total disk space requirements for the processing of one orbit.

	MERIS VA	Doc : Name :MERIS-VA System Architect. Theoretical Basis Document Issue : 1 Rev : 1 Date : 16.3.2000 Page : 38
--	-------------------------------	--

6.2 Plug – In Concept for the MERIS-VA Processor

6.3 Memory Mapped File I/O for Large Files